

# WIRING THE EVO E-3b ESC.

SIMPLIFIED WIRING DIAGRAM DESIGNED FOR USE WITH PLASTIC BODIED LOCOS ONLY.  
 CONTACT **EVO** FOR ADVICE IF YOU WISH TO USE WITH BRASS LOCOS.  
 FOR SAFETY SOLDER ALL CONNECTIONS AND INSULATE THEM.  
 WE HAVE SHOWN THE SWITCH ASSEMBLY FROM THE BIK-U KIT.

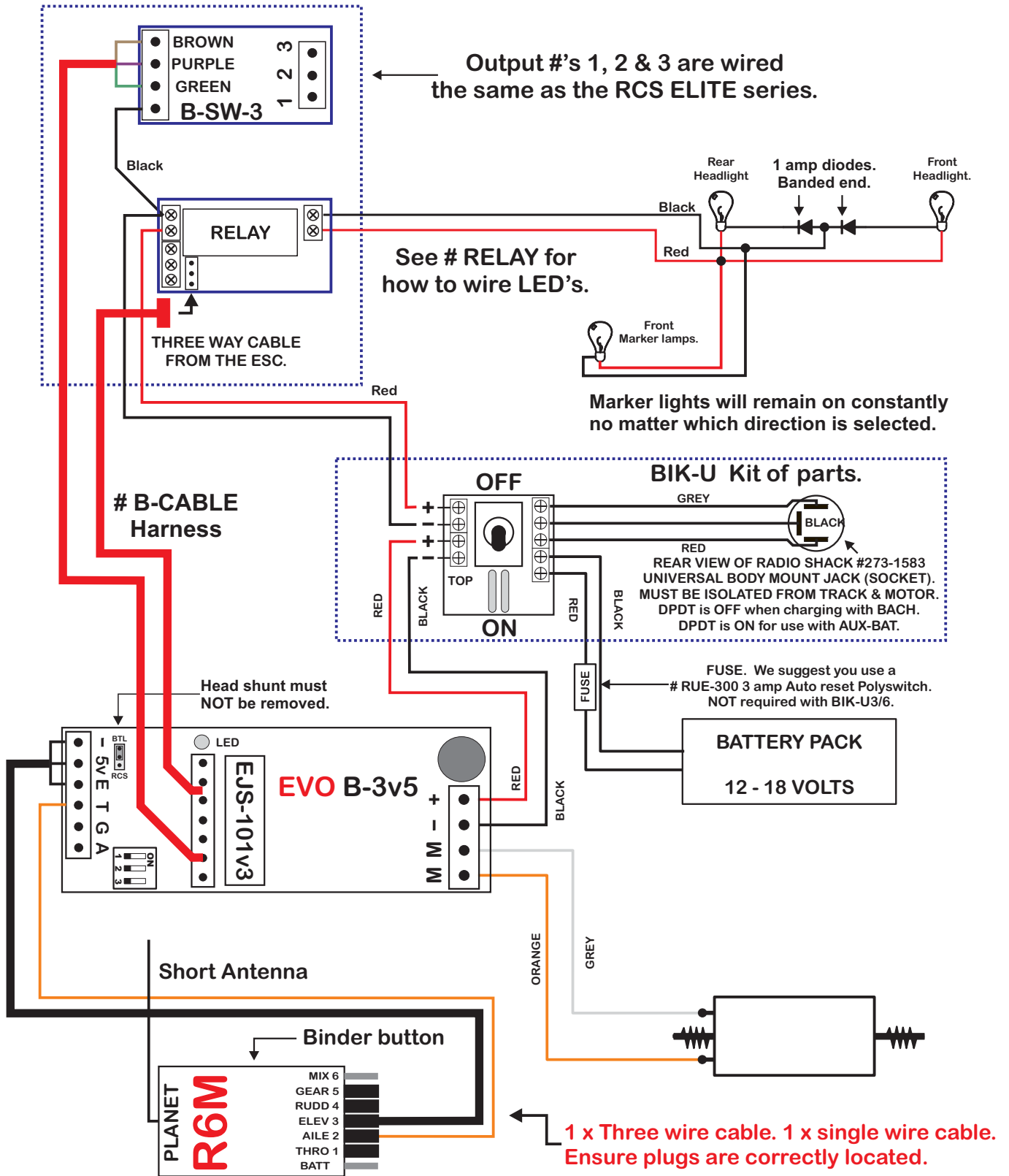

PLEASE NOTE. ORANGE OUTPUT WIRE IS + WHEN DIRECTION IS SET TO FORWARDS.